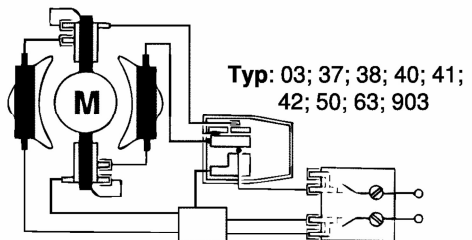
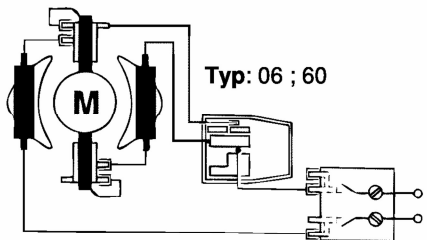
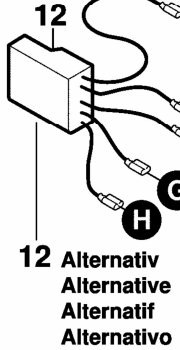
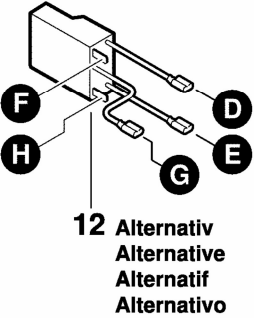
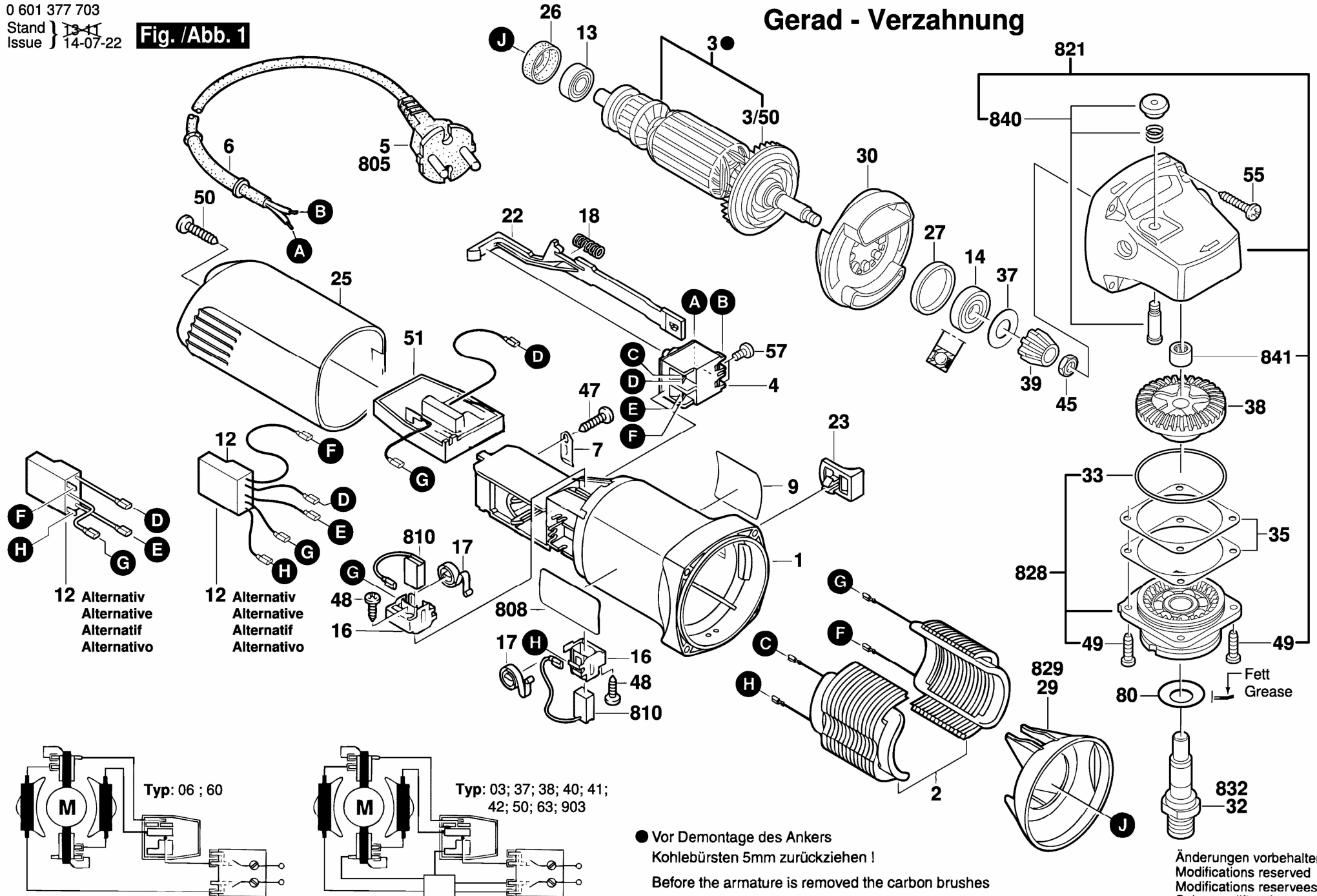

Fig./Abb. 1

Gerad - Verzahnung



● Vor Demontage des Ankers Kohlebürsten 5mm zurückziehen !
Before the armature is removed the carbon brushes must be withdrawn by at least 5mm !

Änderungen vorbehalten
Modifications reserved
Modifications reserves
Salvo modificaciones

Fett
Grease