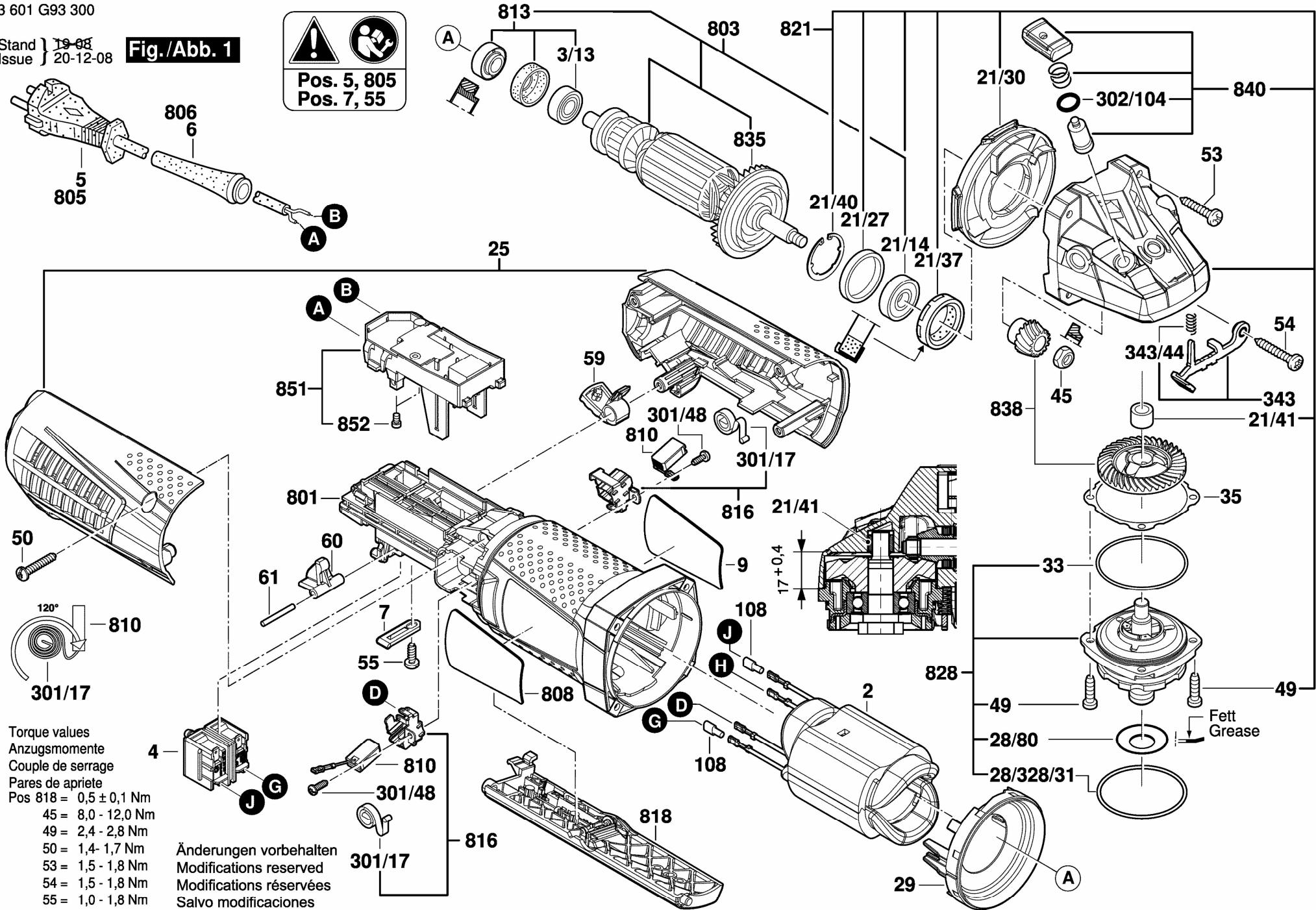

Fig./Abb. 1



- Torque values
Anzugsmomente
Couple de serrage
Pares de apriete
- Pos 818 = 0,5 ± 0,1 Nm
 - 45 = 8,0 - 12,0 Nm
 - 49 = 2,4 - 2,8 Nm
 - 50 = 1,4 - 1,7 Nm
 - 53 = 1,5 - 1,8 Nm
 - 54 = 1,5 - 1,8 Nm
 - 55 = 1,0 - 1,8 Nm

Änderungen vorbehalten
Modifications reserved
Modifications réservées
Salvo modificaciones

Fett Grease