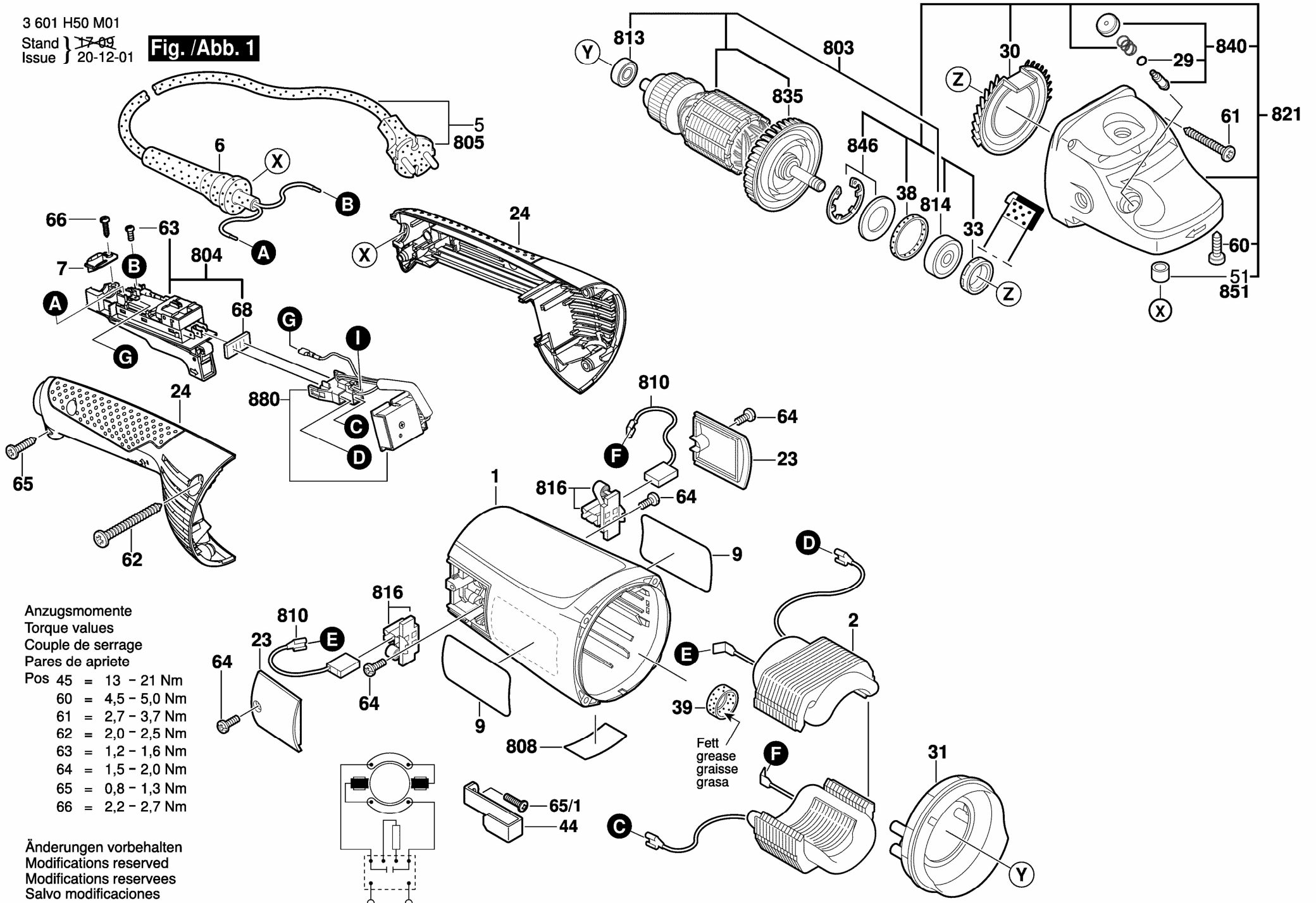

Fig./Abb. 1



- Anzugsmomente
 Torque values
 Couple de serrage
 Pares de apriete
- | | |
|--------|----------------|
| Pos 45 | = 13 - 21 Nm |
| 60 | = 4,5 - 5,0 Nm |
| 61 | = 2,7 - 3,7 Nm |
| 62 | = 2,0 - 2,5 Nm |
| 63 | = 1,2 - 1,6 Nm |
| 64 | = 1,5 - 2,0 Nm |
| 65 | = 0,8 - 1,3 Nm |
| 66 | = 2,2 - 2,7 Nm |

Änderungen vorbehalten
 Modifications reserved
 Modifications reserves
 Salvo modificaciones

Fett
 grease
 graisse
 grasa