

3 601 H84 205

Stand | 18-07
Issue | 20-08-19

Fig. /Abb. 1



Pos. 5, 805
Pos. 7, 66

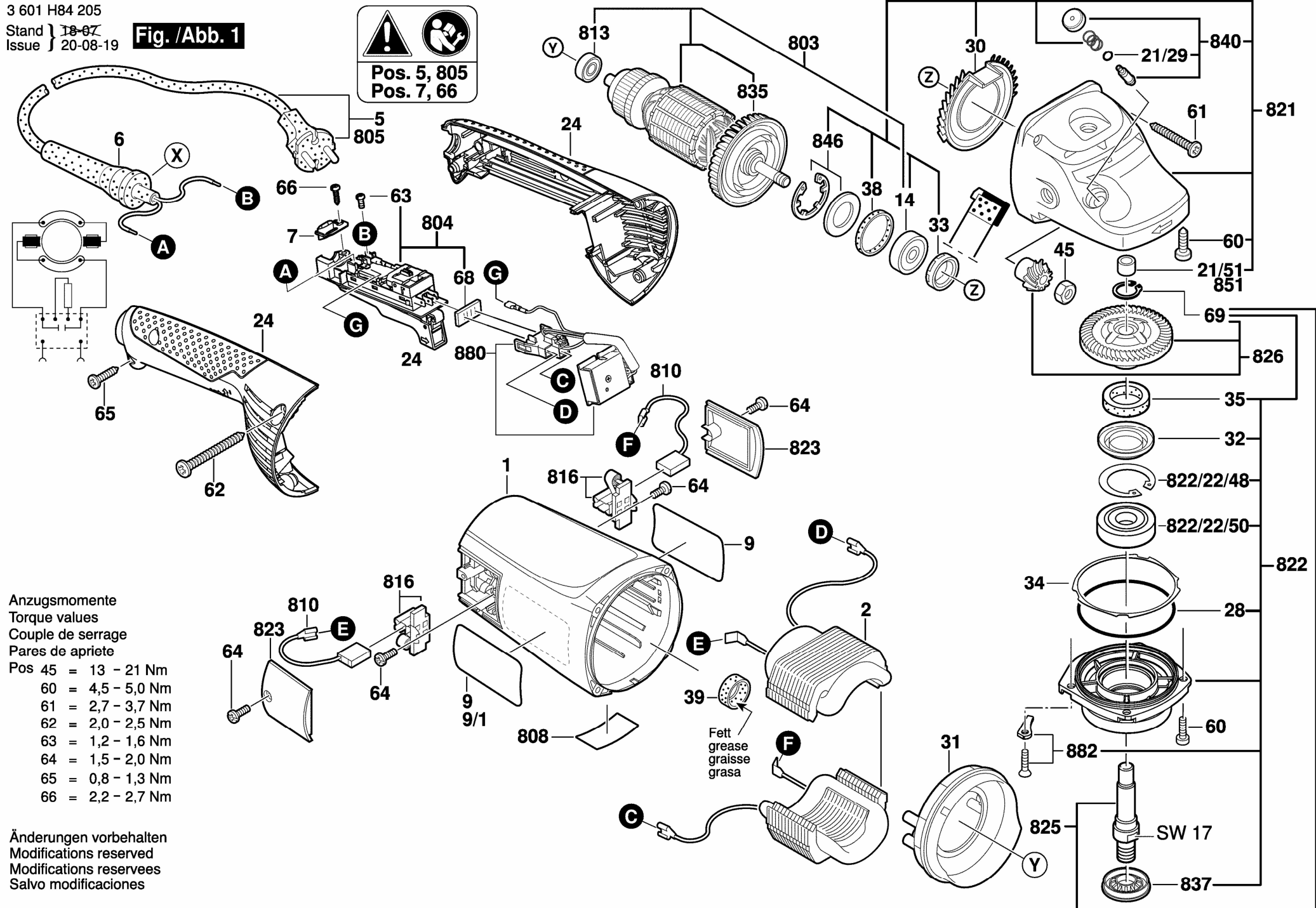

- Anzugsmomente
Torque values
Couple de serrage
Pares de apriete
- Pos 45 = 13 - 21 Nm
 - 60 = 4,5 - 5,0 Nm
 - 61 = 2,7 - 3,7 Nm
 - 62 = 2,0 - 2,5 Nm
 - 63 = 1,2 - 1,6 Nm
 - 64 = 1,5 - 2,0 Nm
 - 65 = 0,8 - 1,3 Nm
 - 66 = 2,2 - 2,7 Nm

Änderungen vorbehalten
Modifications reserved
Modifications reserves
Salvo modificaciones

Fett
grease
graisse
grasa

SW 17